

E-assessment Architecture for Higher Education: A Case Study of University Entrance Exam, Higher Education of Afghanistan

Arzo Mohammadi

Information System, Kabul polytechnic University, Kabul, Afghanistan

Abstract— Afghanistan is one of the developing countries where the traditional assessment system is common in the higher education. The main aim of this study is to demonstrate that which e-assessment architecture can be useful and effective for the higher education sector in Afghanistan. The research method was design science, where 100 questionnaires were distributed for specifying the functional and non-functional requirements of the e-assessment system. Questionnaires were distributed to 50 lecturers, 20 Administrators and 30 graduate students. This study conducted the structured interviews for analyzing the e-assessment architectures and find an applicable and accurate e-assessment architecture for university entrance exam. In this study, interviewed with five participants and the interview has 24 questions. This study used close-ended questions in the interview and considered different perspectives including interoperability, security, reusability, performance, scalability and flexibility for analyzing the e-assessment architectures. After analyze the interview results, this study propose the architecture based on NREN for the university entrance exam of Afghanistan's higher education. This study used the Architecture Tradeoff Analysis Method (ATAM) for the evaluating the e-assessment system architecture based on NREN. For this purpose, ATAM workshop established and evaluated the proposed architecture by fifteen experts. Finally, this study recommended the e-assessment application architecture.

Keywords— E-Assessment, e-learning, Information and Communication Technology, Learning Management System, NREN, AfgREN.

I. INTRODUCTION

Assessment is an essential part of teaching and learning environment. It can measure the progress of students and indicates how people learn. There are different types of assessment and can be used for different purposes. E-assessment is one of the essential components of e-learning to assess student's knowledge. It is worth mentioning that there are different types of e-assessment architectural style, which can be used in e-learning.

This study selects the university entrance exam among the different types of assessment. The university entrance exam is one of the vital exams in the Afghanistan. After the careful study of e-assessment architectures and measure various aspects of them finally this study select the architecture based on NREN and propose it as a suitable architecture for university entrance exam of Afghanistan's higher education. The National Research and Educational Network (NREN) is the appropriate internet infrastructure and service provider for each nation's academic and research community's and it is the main thrust of the academic needs, research, digital libraries, online resources, e-learning, further education, development, voice/video conferencing, knowledge sharing and electronic communication [1].

The e-assessment architecture based on NREN design based on the Model Driven Engineering (MDE) and then evaluate the proposed e-assessment architecture based on Architecture Tradeoff Analysis Method (ATAM). Model Driven Engineering (MDE) is "a software development methodology that focuses on creating and exploiting domain models, which are conceptual models of all the topics related to a specific problem. Hence, it highlights and aims at abstract representations of the knowledge and activities that govern a

particular application domain, rather than the computing (algorithmic) concepts"[2] Architecture Tradeoff Analysis Method (ATAM) is a method which is used for analysis the architectures and it identifies the quality attribute goals based on the business goal and through it analyses how the architectural style achieve these goals [3].

Finally, this study will propose the application architecture for university entrance exam for higher education of Afghanistan.

II. LITERATURE REVIEW

According to Definition (JISC 2006), "Electronic Assessment is the end-to-end electronic assessment processes where ICT is used for the presentation of assessment activity and the recording of responses. This includes the end-to-end assessment process from the perspective of learners, tutors, learning establishments, awarding bodies and regulators, and the general public." It can be Summative, Formative and Diagnostic. Other synonymous terms are Technology-enhanced assessment and computer-assisted or computer-aided assessment. Educational organizations introduced e-assessments over than 16 years ago [4].

There are some of the standalone and web-based LMSs which support some features of the e-assessment system such as WebCT, Blackboard, Moodle and etc. These standalone products don't provide integration and interoperability for the e-assessment system [5]. WebCT and Blackboard are the first-generation solutions of architecture for e-assessment. The strength of them are provided various support services for educators and learners and the

The weakness of these architectures is customized preparing plans custom-made to the learner's goals, background, style and needs, adaptability, pliable access to

lifelong learning as a persistent procedure; concurrent education delivery, new learning models for efficient accretion of education on working environments. The diversity of the approaches and platforms used in these LMSs makes it hard to transfer data between them, the thing that makes some of them outdated and assigned for particular institutions [6].

Modular Object-Oriented Dynamic Learning Environment (Moodle) as presented in a web-based LMS which support various types of assessment such as diagnostic and formative assessment. It also supported peer assessment and self-assessment. Students can submit the assignments and get feedback from the teacher [7].

Traditional e-assessment systems had many challenges such as data privacy and security, performance, scalability and accurate evaluation. The service oriented architecture is the third generation of e-assessment architectures which some issues such as resource provisioning, overall system cost and optimum resource utilization but scalability is the main challenge of it for example when the numbers of students demands increased the administrator should upgrade the server infrastructure and enable its robustness. cloud-based architecture is the fourth generation of e-assessment architectures which provides better performance, scalability, flexibility and reduce overall costs [8]. The Cloud-based e-assessment architecture is not a new idea. Gierlowsky designed a modular architecture with several modules and layers which are high scalable [9].

Armenski and Gusev (2009) presented ultimate e-Assessment system which it is a new high level of architecture's abstraction. The fundamental emphasis is set of internal and external domain interoperability to build standalone system or a cloud solution. They innovated in the field of communication of a broker with another different LMSs. a broker can act as a regulator of service using description about available services, service registry and Description Discovery and Integration (UDDI). The Ultimate e-assessment system is three layered architectures which the layers are common services layer, e-Assessment services layer and composite services layer (Broker) and also FREMA Project described most of the e-assessment services in the Common service layer. Recently, Ristove et al defined a cloud solution for e-assessment which consist three subsystems such as the Management, Assessment and Reporting subsystems and instead of one broker defined and an organization-scheduling algorithm for different Virtual Machines (VMs). for communication between virtual machines defined Administrator, Students and Reporting agents and also the teacher, student and administrator can communicate with agents. For resource provisioning defined Infrastructure agent [8].

The public cloud is not fully under the control of the owner, and thus, the ownership of resources is an issue. While e-testing needs a secure and controllable infrastructure, the public cloud is not as secure, reliable, interoperable and flexible as it should be.

Jorge Miguel, Santi Caballe et al. (2015) proposes an innovative approach for modelling trustworthiness in the context of secure learning assessment in on-line collaborative

learning groups, but the network part and data mining remain an open question. The online learning with adaptive testing is a system where questions are stored in a database, and students can learn and pass the test based on web services.

Antonio J. Sierra, et al. propose the integration of new module with LMS by using the LTI to support assessments [10].

Muhammad Arif and et al. (2015) propose an integrated e-learning and e-testing system. They consider a five-layer client-server based architecture. The e-learning architecture layers are the interface layer, the resource layer, the multi-agent layer, the database layer and the database controller layer. The architectural layers of e-testing are the human user interface layer, the user and admin resource agent, the functional description layer, the implementation layer and the database layer. The human user interface layer is an interface which the user and the admin can login to the system. The user can select a form of questions and pass various types of exams. The user and admin layer establish a communication between students and employers which, the students can post their profiles and the employer can post their vacancies for employees. They use the intelligent agent so that the progress and performance of students can also be checked. Functional description layer is another part of this architecture that operates as a controller of questions bank. The proposed system is considered some specific characteristics for e-learning system such as interoperability, interaction, personalization, adaption, intelligence, accessibility and security. According to [12] the study proposed a new approach to the personalized and generic e-assessment process. They used existing learning management systems and propose the adoption of these systems to cloud computing, but they do not sufficiently analyze e-assessment using cloud computing.

According to [13] the researcher proposed an e-assessment architecture based on NREN. They designed the university entrance exam based on AfgREN. This can be implemented also in other assessments, as well as in other countries. The e-assessment architecture based on AfgREN has a three-layer style which comprises an internal, conceptual and external layer. On the external layer, the e-testing_Exchange component comprises a component for distributed e-testing process enactment. The e-test_Exchange component contains a rules engine which supports the distributed e-testing process enactment engine. A trusted third party exists in the middle in the form of an e-test_Broker component to enable the setup phase of an e-test collaboration. The conceptual layer contains an eLearning_Setup_Support component, translator and the internal layer contains Legacy_Management, Local rule engines and local database systems. The eLearning_Setup_Support component in which e-learning services are composed collaboratively in a crowd-sourcing way. The Translator component converts heterogeneous data formats between the external- and internal layer. The Legacy_Management component in which local process enactment engines orchestrate information technology infrastructure that is wrapped as a Web-service. There are local rules engines and local database systems in the internal layer.

III. RESEARCH QUESTIONS

This study includes four main research questions. The first research question aims to understand “How to design a nationwide e-assessment architecture for higher education of Afghanistan to increase transparency, interoperability and accountability?”; The second research question aims to define

What are the functional and non-functional requirements for e-assessment system based on NREN?”; The third question aims to reveal that “Which quality attribute goals covered by the proposed e-assessment system architecture?”; And the fourth research question aims to find “How to design a nationwide e-assessment application architecture for university entrance exam of Afghanistan?”.

IV. RESEARCH METHODOLOGY

This study used design science as the research methodology. Design science research is primarily research using design as a research method or technique. Design science research is used in many different fields such as education, engineering, healthcare, architecture, computer science, fine arts and psychology [11].

The quantitative elements were designed based on using questionnaires as main tools and the qualitative elements of this research were based mainly on interviews.

In order to functional and non-functional requirement for the e-assessment system the researcher selected are Ministry of higher education, some higher education institutes, including Kabul polytechnic university, Kabul university and Kabul Education university as a case study area. The total population that was considered for this study includes 100 participants, which consists of 50 lecturers, 20 Administrators and 30 graduate students.

The primary data is gathered using online questionnaire with close-ended questions and the result is presented quantitatively by percentages. The gathered questionnaires were analyzed by researchers using Microsoft Excel. The qualitative data is collected by structured interview and the interview questions were close-ended questions and considered different respective including interoperability, security, reusability, performance, scalability and flexibility in. Finally, this study used ATAM Workshop for evaluating the proposed e-assessment system architecture.

V. FINDINGS AND DISCUSSION

This research aimed at propose the system and application architecture based on the AfgREN for e-assessment in particular university entrance exam for Higher Education of Afghanistan. Here we discussed the study findings in order to answer the research questions.

A. Design a nationwide e-assessment architecture for higher education of Afghanistan

This study select the e-assessment architecture based on NREN for the university entrance exam of Afghanistan from the interview results. Finding about the interview conducted with the experts about the analysis the e-assessment architectures and select one of them as the suitable and applicable architecture for the e-assessment in particular for

the university entrance exam of Afghanistan indicated that they selected the e-assessment architecture based on NREN for the university entrance exam. This study analyzed four e-assessment architectures, including monolithic, modular, service-oriented and e-assessment architecture based on NREN regarding the following quality attributes: interoperability, security, reusability, performance, scalability and flexibility. As most of the participants preferred the e-assessment architecture based on NREN as the applicable and suitable for the university entrance exam of Afghanistan. Table I shows the result of analysis the e-assessment architectures.

TABLE I. Analysis the e-assessment architectures

Quality attributes	First generation (Monolithic)	Second generation (Modular)	Third generation (Service-oriented)	cloud based architecture (based on NREN)
Interoperability	L	L	M	H
Security	L	L	M	H
Reusability	L	M	H	H
Performance	L	L	M	H
Scalability	L	L	L	H
Flexibility	L	L	M	H

B. Functional and non-functional requirements

Functional requirements cover the specific behavior of systems while non-functional requirements specify criteria for judging the operation of a system, rather than specific behaviors and the functional requirements and non-functional requirements for the e-assessment system adapted from [12].

The functional requirements for e-assessment system are verification result announcement for the user, Verifying the collaboration parties and exchangeable components, Brokering capability for the projected services, Project the e-learning services from conceptual layer of each collaboration party to external layer, Translate the existing legacy system to a technical system and mapping them between collaboration parties, Support for conceptual formulation of e-learning services between collaboration parties based on accepted agreement and existing procedure, Secure network, High performance and management.

The non-functional requirements for the e-assessment systems are Interoperability, Modifiability, Scalability, Integrtatability, Performance and Security [13].

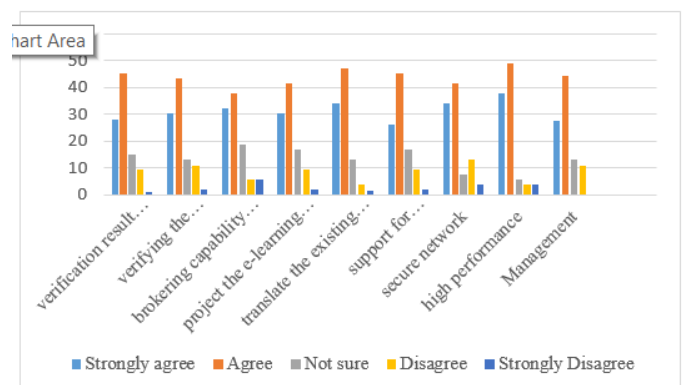

Fig. 1. Participants' responses about the functional requirements for e-assessment architecture on NREN

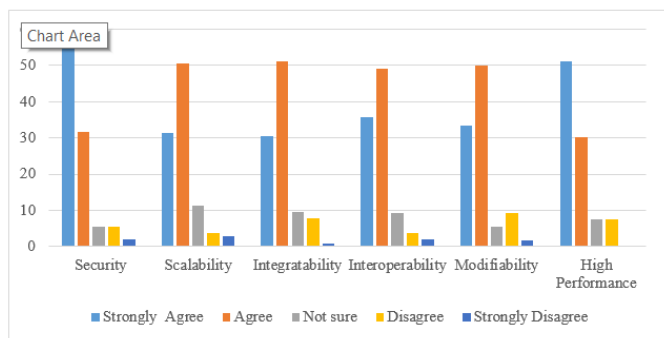

Fig. 2. Participants' responses about the functional requirements for e-assessment architecture on NREN

C. Quality attributes goals of the e-assessment architecture

This study used the Architecture Tradeoff Analysis Method (ATAM) method for analyzing and evaluating the e-assessment system architecture with related functional and non-functional requirements in a qualitative and empirical way. ATAM often is used for investigating the use of best-practice for quality attributes of architectural style and analyzing the legacy systems.

Based on the results of ATAM workshops about the evaluation and validation the e-assessment architecture based on NREN we found this architecture support the following quality attributes: interoperability, modifiability, Integratability, scalability and security. As well as we found the risks, non -risks, sensitivity and trade off points of this architecture.

As the architecture has the replicated components in the external layer for support interoperability quality attribute. As well as on the conceptual layer the pipes and filters pattern facilitates establishing communication channels between the external and internal layer via the conceptual layer and via this pattern support the modifiability and Integratability. Furthermore, e-test broker in this architecture support the scalability and regarding the architecture contains the coordination interface in the external layer that it is security façade for protecting a collaborating party from cyber security threats support security quality attribute.

The result of the ATAM workshops indicated the risks of the e-assessment architecture based on NREN that they found the security risks in particular trust management risks and modifiability risks that can be averted by using the socio-technical software agents. As well as they indicated the non-risks in security by using the coordination interface component and modifiability by proposing the abstract data repository style. Furthermore, they found the sensitivity points in this architecture that they are sensitive to availability because the brokering is essential for availability and when e-test broker fails there is sensitive to availability and also failing databases for example databases that contains business rules and processes sensitive to modifiability of this architecture and finally large collaboration configurations may pose a challenge to performance during verification. The tradeoff points perceived by the workshop participants include brokering in the quick matching for pose the security challenges and modifying the business rules for pose the

performance challenges.

D. Design a nationwide e-assessment application architecture for university entrance exam of Afghanistan

An architecture is a description of components, functions and connections among functional components that comprise an overall system [14].

A pattern provides a solution on an architectural level and it serves as a guideline for developing a high-quality specification of new e-learning systems (Norta, Mahunnah, Tenso, Taveter, & Narendra, 2014). The proposed infrastructure for the university entrance exam of Afghanistan. Based on this architecture, the related organizations including the MoE, the MoHE and universities can exchange data in a secure, reliable, high- performance network. This architecture adapted from the eSourcing Reference Architecture eSRA [15] and shows a three-layer style which comprises an internal-, conceptual, and the external layer.

Application architecture describes the structure and behavior of applications used in a business, focused on how they interact with each other and with users. It is focused on the data consumed and produced by applications rather than their internal structure. In application portfolio management, the applications are usually mapped to business functions and to the application [16]. The proposed application architecture as illustrated comprises three layers, including presentation layer, business layer and persistence layer. We consider assessment analytics, portal, core standards and identifier management in the presentation layer. The business layer contains Item bank, Item Authoring, Test Authoring, Test Registration, Test Delivery, Test Spec Bank, Machine Scoring, Monitoring & Alerting and Collaboration. The persistence layer (Data Access Layer) comprises SSO and Adaptive Engine. We consider HRM and Financials in the Batch section. The integration section contains integration with LMS's and Integration with Analytic tools. The external systems are Bank, Facebook and SMSC for messaging. The data sources in this application architecture are OLAP and OLTP. We consider Security in the cross-cutting section and finally test candidate, Author and administrator are the users of the application.

Meier and et al (2010) defined the presentation layer as "The presentation layer contains the components that implement and display the user interface and manage user interaction. This layer includes controls for user input and display, in addition to components that organize user interaction". The portal is the main entry point of the e-assessment system. The end-users can access the components of the e-assessment system from there. It controls the user has access to which components. It permits the show of information and furthermore dashboard widgets from numerous different components. The core standards are a component of the e-assessment system that manages the core standards that the other components reference and furthermore utilize them in the similar estate. This component is the single adaptation of truth to these standards. Whenever a component needs to reference a core standard, it will utilize the identifiers and content which have been recovered from Core Standards

component. Because the e-assessment system needs to integrate with other legacy systems, so the identifier management component is used in the e-assessment system. Since This component store, a mapping between the e-assessment system based on NREN and other e-assessment legacy systems, the e-assessment architecture based on NREN components can depend on their own identifiers furthermore managed in one centralized location [16]. The business layer applies the application’s business functionality. The Item Bank component store and retrieve assessment items, properties and metadata related to the assessment items. Furthermore, this component explores item versioning and item lineage it means if an item changed it become a new item the lineage explore what item used to be. The item bank tracks all changes. It provides powerful search for the item based on any metadata field. The Item Authoring interacts with the Item Bank component. It is a graphical interface utilized for the authoring and workflow of the item development. The Test Authoring is a graphical interface utilized for making the test specifications and drafts and also control the workflow. The Test Registration component registers the test candidates for the university entrance exam. The Test Spec Bank is a repository for all data about the test, including drafts, requirements and so on. The Machine Scoring is used for scoring the answer sheets and currently, is used the OMR machine for the scoring the answer sheets. The Test Delivery is used for firmly deliver the test to the test candidates and also deliver the test items in the appropriate comprehensible format to the test candidates. Furthermore, this component stores the test candidate responses and further information about how the test candidate responded. The Monitoring & Alerting services permit the components to send alerts and monitor the alerts in a stable way. The Collaboration service allows the components coordinated work together [16].

The persistence (Data access) layer provides access to the databases or data warehouses. The persistence layer of the proposed application architecture contains the Single Sign-on and Adaptive Engine. Single Sign-on (SSO) is used for user authentication for each user interface. This component allows the user only once sign in to the e-assessment system and use the authorized components. Adaptive Engine is the adaptive algorithm implementation. Various security types are required for the e-assessment system, including Component-to-component, User authentication and authorization, Item-level security. Each E-assessment application architecture component is connected to other components of the system. The communication channel between the components must guarantee that those components can’t be snooped and or spoofed. It needs to be considered some techniques such as IP filtering, SSL, PGP, SAML and so on [16].

IP filtering is a mechanism that determines which kinds of IP datagrams will be handled typically and which will be deleted and ignored. The SSL is a security protocol that determines the variables of the link and data encryption before the data transferred. The PGP is a popular encryption program is used to cryptographic privacy and authentication for data communication [17].

The SAML is a standard for exchange the authentication

and authorization data between the security domains and support single sign-on [18].

User authentication and authorization is another type of security that must be considered in the e-assessment system. The users must be authenticated to the e-assessment system and authorized to use the functionalities and features of components. There is used SSO as an authentication and authorization solution. Another type of security must be considered in the e-assessment system is the item-level security. It is important that just authorized users with the right level of privileges can work on the items and also it must be considered the manner of transmission the data to the other systems and furthermore the manner of authentication and authorization of those systems [16].

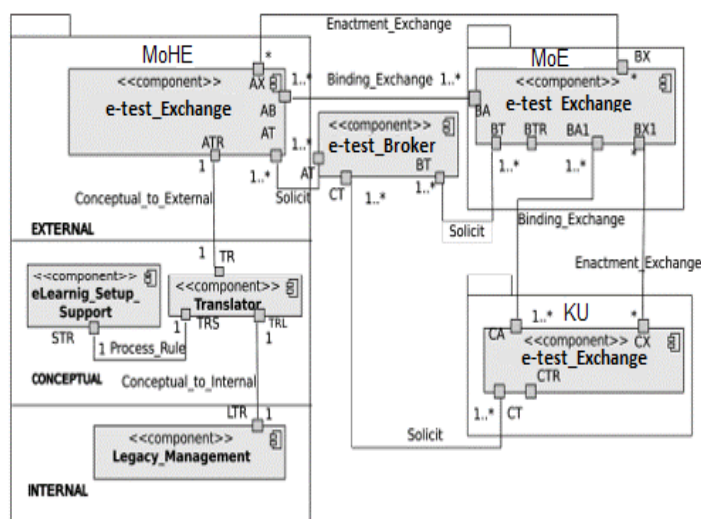

Fig. 3. E-Assessment architecture based on NREN [13].

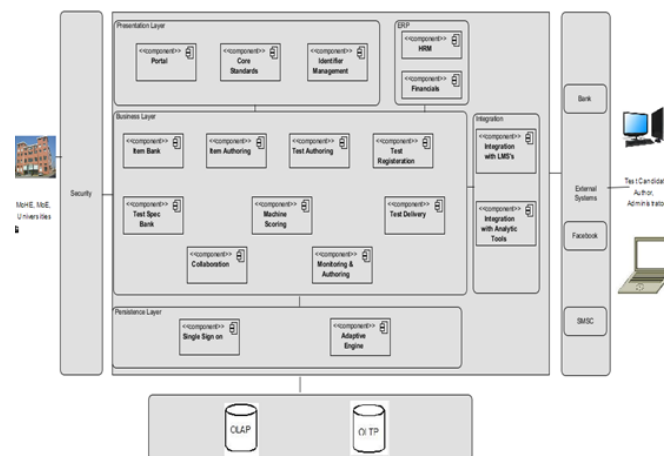

Fig. 4. E-assessment application architecture adapted from [16].

The data warehouse stores the information moved from the test delivery component. A data warehouse is a “subject-oriented, integrated, time varying, non-volatile collection of data that is used primarily in organizational decision making” [18]. The data warehouse support OLAP for the functional and performance requirements and OLTP that traditionally supported by the operational databases. The OLTP provide source data to the data warehouse and OLAP help to analyze

data. The OLAP is used for interactive analysis of multidimensional data and it is a vital element for decision support and data mining and furthermore OLAP is used for data analysis by knowledge makers whereas the OLTP is customer oriented and is used for transaction and query processing by clients and IT professionals [19]. The OLTP systems are used to store data whereas ensuring the concurrency and arrange the number of transactions and OLAP systems is used for multidimensional data analysis. The OLTP systems allow concurrent examination from the biggest group of test candidates in the e-assessment system [20].

VI. CONCLUSION

In this study we propose an architecture for university entrance exam in the higher education of Afghanistan to face the current challenges such as interoperability of the information systems of relevant organizations including MoE, MoHE and universities, Security of examination that caused the administrators can't use the we-based cancour system with all of components and features and so on.

The findings of the research indicated the functional and non-functional requirements for e-assesment architecture on NREN and evaluated the e-assesment architectures and recommended the e-assesment architecture on NREN and finally, proposed the e-assesment application architecture.

The researcher should use a method for analyzing and validating the e-assessment application architecture. since it used ATAM method for validating the e-assessment system architecture so it would be helpful for the further researcher use the ATAM method. The ATAM method focus on the quality attribute requirements. The ATAM method includes the following steps: (1) Present the ATAM, (2) Present business drivers, (3) Present architecture, (4) Identify architectural approaches, (5) Generate quality attribute utility tree, (6) Analyze architectural approaches, (7) Brainstorm and prioritize scenarios, (8) Analyze architectural approaches and (9) Present the results. In the first step, the method is described to the assembled stakeholders that they can be customer representatives, the architect or architecture team, user representatives, administrators, managers, testers, integrators and so on [21].

Findings of this study will help people involved in implementing and validating the e-assessment application architecture for the university entrance exam discussed in the below.

REFERENCES

[1] M. T. Meeran, "Afghanistan Research and Educational Network (AfgREN) infrastructure," 2013. Accessed on: Aug., 22, 2020. [Online]

[2] D. C. Schmidt, "Model- Driven Engineering," 2016.

[3] R. Kazman, M. Klein, and P. Clements, "ATAM: Method for architecture evaluation," Software Engineering Institute, Carnegie Mellon University, Pittsburgh, Pennsylvania, Technical Report CMU/SEI-2000-TR-004, 2000.

[4] M. Gusev and G. Armenski, "E-assessment systems and online learning with adaptive testing ", *E-Learning Paradigms and Applications*, pp. 229-249, 2014.

[5] P. Cristea and R. Tuduce, "Automatic generation of exercises for self-testing in adaptive e-learning systems", *Exercises on AC Circuits', Third International Workshop on Authoring of Adaptive and Adaptable Educational Hypermedia*, 2005.

[6] M. Amelung, K. Krieger, and D. Rösner, "E-Assessment as a Service," *IEEE Transactions on Learning Technologies*, vol.4, issue.2, pp. 162-174, 2011.

[7] J. Ramos, M. A. Trenas, E. Gutiérrez and S. Romero, "E-assessment of Matlab assignments in Moodle: Application to an introductory programming course for engineers," *Computer Applications in Engineering Education*, vol. 21, issue.4, pages 728-736, 2013.

[8] M. Gusev, S. Ristov, G. Arminski, G. Velkoski, and K. Bozinoski, "e-Assessment Cloud Solution: Architecture, Organization and Cost Model", in *EDUCON*, vol. 8, pp. 55-64, 2013.

[9] K. Gierlowski and K. Nowicki, "A highly scalable, modular architecture for computer aided assessment e-learning systems," *Distance Education Environments and Emerging Software Systems: New Technologies, IGI Global*, 2011.

[10] J. Sierra, Á. Martín-Rodríguez, T. Ariza, J. Muñoz-Calle, and F. J. Fernández-Jiménez, "LTI for Interoperating e-Assessment Tools with LMS," in *MIS4TE*, pp.173-181, 2016.

[11] V. Vaishnavi and B. Kuechler, *Design science Research in Information Systems*, 2013.

[12] A. Norta, P. Grefen, and N. C. Narendra, "A reference architecture for managing dynamic inter-organizational business processes", in *Data & Knowledge Engineering*, vol. 91, pp. 52-89, 2014.

[13] S. Saay, A. Norta, and M. Laanpere, "Requirements for e-testing services in the AfgREN cloud-based e-learning system," in *ICAAC*, 2016.

[14] E. Castelán Maldonado, M. Á. Brigos Hermida, and J. Fernández Sánchez, "A software reference architecture for the design and development of mobile workflow learning applications," in *INTED2014 Proceedings*, pp. 6351-6360, 2014.

[15] A. Norta, M. Mahunnah, T. Tenso, K. Taveter, and N. C. Narendra, "An agent-oriented method for designing large socio-technical service-ecosystems," in *SERVICES*, pp. 242-249, 2014.

[16] *Assessment System Architecture and Technology Phase 1 Report*, measured progress, 2012.

[17] S. Garfinkel, "PGP: pretty good privacy," O'Reilly Media, Inc., 1995.

[18] W.H. Inmon, "Building the Data Warehouse," 2nd ed., New York: John Wiley & Sons, 1996.

[19] S. Saagari, P. D. Anusha, C. L. Priyanka, and V. S. S. N. Sailaja, "Data Warehousing, Data Mining, OLAP and OLTP Technologies Are Essential Elements to Support Decision-Making Process in Industries. *International Journal of Innovative Technology and Exploring Engineering*, vol.2, issue. 6, pp. 88-93, 2013.

[20] K. Szumigaj, "VII. Project of reporting and evaluation data," *Innovation management*, v. 109, 2015

[21] S. A. Andreasson, "SOFTWARE ARCHITECTURE ATAM: Method for Architecture Evaluation".2009.